

## FyreWrap® Cable Insulation

### Introduction

Unifrax's FyreWrap® Cable Insulation is a thin, flexible, insulation wrap designed to provide a fire-protective enclosure around cable trays and conduit. The FyreWrap system ensures electrical circuit integrity during exposure to an external hydrocarbon fire, permitting continued operation or controlled shutdown of critical equipment during emergency conditions. This system is FM Global Approved and meets ASTM E-1725 "Fire Tests of Fire-Resistive Barrier Systems for Electrical System Components," the newest industry standard, requiring the highest level of performance for trays with zero to full cable loading. The system also meets ASTM E-1529 and provides circuit integrity ratings. FyreWrap complies with many industry specifications on fireproofing for petroleum and petrochemical processing plants.

### Product Components

**Core Material:** FyreWrap Cable Insulation products incorporate Insulfrax® Thermal Insulation as its core material. Insulfrax is a high-temperature insulation made from calcia, magnesia, silica chemistry designed to enhance biosolubility. It provides excellent insulation in a noncombustible blanket form.

**Encapsulating Material:** The core insulation is completely encapsulated in an aluminum foil, fiberglass-reinforced scrim covering. This scrim provides additional handling strength as well as protection from tearing and moisture absorption. For outdoor installations, additional weather protection should be considered.

### Typical System Properties

FM Global Approved – Wrap for Grouped Electrical Cables

Fire Ratings – 15, 30, 45 and 60 minutes  
(contact Unifrax for details)

Fire Exposure – Hydrocarbon Fire per ASTM E-1529

Circuit Integrity – per ASTM E-1529

Temperature Integrity – per ASTM E-1725

Cable Loading – Empty to Fully Loaded Trays

ASTM E-84 Surface Burning Characteristics:

Unfaced Core: Flame/Smoke Rating = Zero

FyreWrap: Flame/Smoke Rating < 25/50



### Typical Product Parameters

|                       |  |
|-----------------------|--|
| Thickness             | 1.5", 2.0"   |
| Density               | 8pcf   |
| Standard Product Form | Scrim Encapsulated   |
| Product Availability  | 1.5" x 24" w x 25 LF<br>1.5" x 48" w x 25 LF<br>2" x 24" w x 20 LF<br>2" x 48" w x 20 LF |

Refer to the product Material Safety Data Sheet (MSDS) for recommended work practices and other product safety information.

## FyreWrap® Cable Insulation Single-Layer System Installation

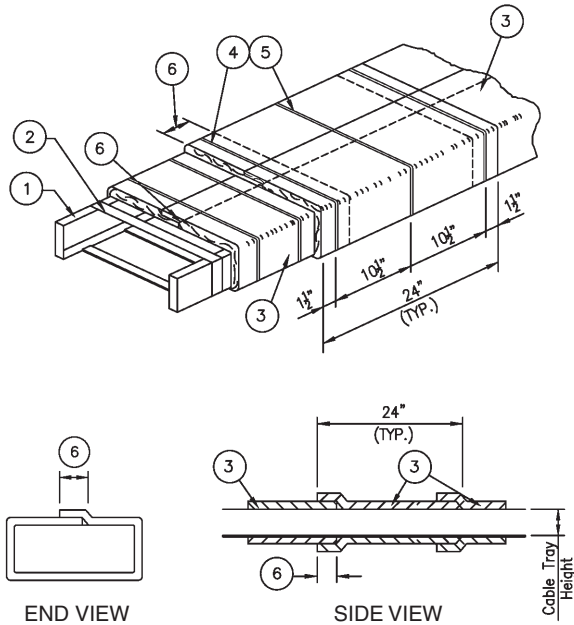

| ITEM | DESCRIPTION   |
|------|---|
| 1    | Cable Tray, 14 gauge SS Ladderback or solid bottom, empty to full cable loading |
| 2    | Banding Straps, wire mesh or cable tray cover (optional)                        |
| 3    | FyreWrap Cable Insulation Single-Layer Installation                             |
| 4    | Filament Tape, 1" wide (Temporary Hold)   |
| 5    | SS Banding Straps, (Permanent Hold), Type 302, min. 1/2" wide x .015" thick     |
| 6    | 3" perimeter and longitudinal joint overlaps                                    |

Figure 1. Single-Layer System Installation



## Installation

To prevent material sagging on open cable trays (no lids), steel banding is installed around the cable perimeter prior to application of the insulation blanket. Banding is tightened to create a surface for the insulation blanket to rest upon. The use of wire mesh or a cable tray lid is also permitted.

### Single-Layer System:

The FyreWrap Cable Insulation single-layer systems are applied directly around the exterior perimeter of the cable tray. All material overlaps must be a minimum 3". To minimize waste, FyreWrap should be rolled out tautly before measuring. Cut the insulation to a length sufficient to wrap around the tray plus a minimum 3" longitudinal material overlap. Seal all cut edges with aluminum foil tape to ensure there is no exposed fiber. Adjacent pieces of insulation must overlap onto the previous piece to form a minimum 3" perimeter material overlap.

Once the insulation blanket is in place, it may be temporarily secured with the optional use of 1" wide filament tape. Locate the tape within 1.5" of the insulation edge and in the center of the insulation blanket width. Stainless steel banding (min. 0.5" wide, min. 0.015" thick) must be utilized on the outside of the insulation as a permanent attachment. Center bands over the material overlaps, approximately 1.5" from the insulation edge. An additional band shall be located within the field between overlaps, approximately 10.5" on center. This band spacing should be used for straight cable tray runs and on bends. Utilize band tensioning tools and crimp clips to tighten the banding around the insulation and secure in place. See Figure 1 for details.



Thermal Products Company, Inc.  
4520 S. Berkeley Lake Rd.  
Berkeley Lake, GA 30071-1639  
770-662-0456  
770-242-6210 (Fax)  
info@thermalproductsco.com  
www.thermalproductsco.com

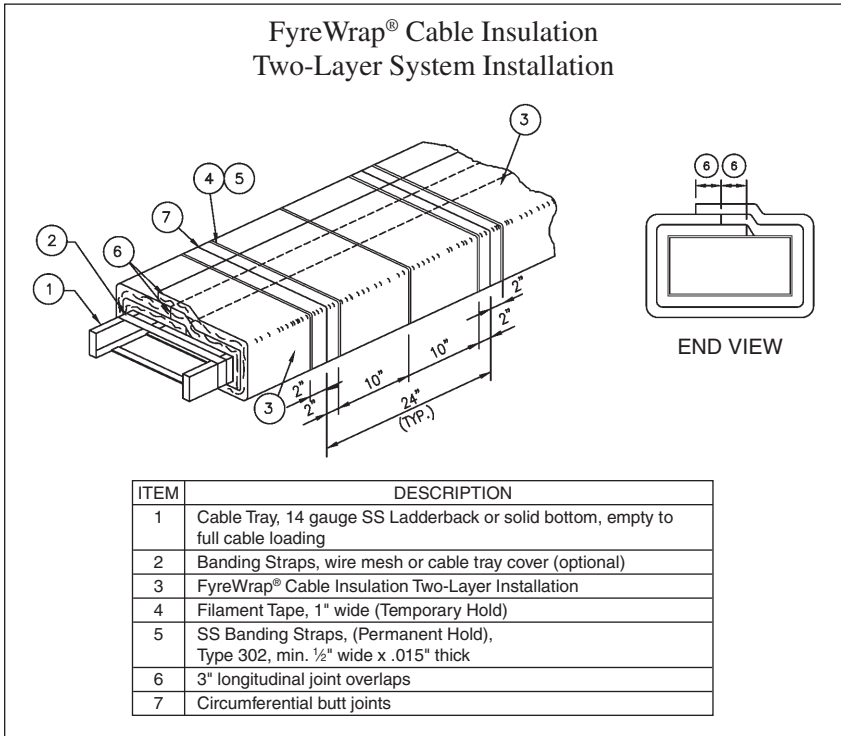

**Figure 2. Two-Layer System Installation**

**Two-Layer System:**

The FyreWrap Cable Insulation two-layer system is applied directly around the exterior perimeter of the cable tray. All perimeter material overlaps utilize a compression butt joint. All longitudinal material seams are overlapped a minimum 3". To minimize waste, FyreWrap should be rolled out tautly before measuring. Seal all cut edges with aluminum foil tape to ensure there is no exposed fiber.

Once the insulation is in place, it may be temporarily secured with the optional use of 1" wide filament tape. Locate the tape 2" from the insulation perimeter butt joint and in the center of the insulation blanket width, approximately 10" on center. Stainless steel banding (min. 0.5" wide, min. 0.015" thick) must be utilized on the outside of the insulation as a permanent attachment. Locate bands 2" from the perimeter insulation butt joint and in the blanket width between bands, approximately 10" on center. This band spacing should be used for straight cable tray runs and on bends. Utilize band tensioning tools and crimp clips to tighten around the insulation and secure in place. See Figure 2 for details.

**Testing Results**

For additional information on FyreWrap Cable Insulation, fire test results, independent laboratory certifications or compliance to industry specifications, please contact the Unifrax Application Engineering Group at 716-278-3888.



**Thermal Products Company, Inc.**  
 4520 S. Berkeley Lake Rd.  
 Berkeley Lake, GA 30071-1639  
 770-662-0456  
 770-242-6210 (Fax)  
 info@thermalproductsco.com  
 www.thermalproductsco.com





## Other Fire Protection Products and Applications

Unifrax offers many UL-listed Fiberfrax® and FyreWrap® product forms and FyreWrap fire protection materials for passive fire protection applications, such as:

| Product                                       | UL File Number |
|---|----------------|
| FyreWrap® Duct Insulation                     | R14514         |
| Insulfrax® S Blanket                          | R14514         |
| Fiberfrax® XFP® – Expanding Fyre Paper        | R15435         |
| Fiberfrax® Durablanket® Ceramic Fiber Blanket | R14514         |
| Fiberfrax® Duraboard® Ceramic Fiber Board LD  | E75289         |
| Fiberfrax® Ceramic Fiber Papers (110/440)     | E75289         |
| Fiberfrax® Ceramic Fiber Papers (970)         | MH7030         |
| Fiberfrax® Lo-Con™ Felt                       | MH7030         |
| Fiberfrax® Moist Pak-D®                       | E75289         |

These products offer solutions in applications such as:

- Grease, HVAC Ducts
- Cable Trays, Conduit
- Control System Covers
- Above Ground Storage Tanks
- Marine Bulkheads, Decks
- Structural Steel
- Construction Joints
- Curtain Walls/Safing
- Circuit Protection
- Railroad Tank Cars
- Transit Cars
- Ships
- Expansion Joints
- Fire Door Seals
- Chimney Liners
- Ceiling Air Diffusers
- Hazardous Material Storage Containers



**Thermal Products Company, Inc.**  
**4520 S. Berkeley Lake Rd.**  
**Berkeley Lake, GA 30071-1639**  
**770-662-0456**  
**770-242-6210 (Fax)**  
**info@thermalproductsco.com**  
**www.thermalproductsco.com**



Unifrax has a wide range of FyreWrap protection materials available to provide passive fire protection solutions in a variety of applications in the commercial building, industrial facility and transportation industries.

For additional information about product performance or to identify the recommended product for your fire protection application, please contact the Unifrax Application Engineering Group at 716-278-3888.

Data are average results of tests conducted under standard procedures and are subject to variation. Results should not be used for specification purposes.

Form C-1449  
 Effective 1/10  
 © 2007-2010 Unifrax I LLC  
 All Rights Reserved  
 Printed in USA  
 Page 4 of 4

The following are registered trademarks of Unifrax: FyreWrap, Insulfrax, XFP, Lo-Con, Moist Pak-D, Fiberfrax, Durablanket, and Duraboard.

The test data shown are average results of tests conducted under standard procedures and are subject to variation. Results should not be used for specification purposes.

Product Information Sheets are periodically updated by Unifrax. Before relying on any data or other information in this Product Information Sheet, you should confirm that it is still current and has not been superseded. A Product Information Sheet that has been superseded may contain incorrect, obsolete and/or irrelevant data and other information.



**Unifrax I LLC**  
 Corporate Headquarters  
 2351 Whirlpool Street  
 Niagara Falls, New York 14305-2413  
 Telephone: 716-278-3800  
 Telefax: 716-278-3900  
 Internet: [www.unifrax.com](http://www.unifrax.com)  
 Email: [info@unifrax.com](mailto:info@unifrax.com)